

Installation Guide



Before you start...

Do not remove the door from the packaging until you have checked:

- The paperwork to ensure it's the right specification.
- The sizes are correct before the existing door is removed.
- And you've checked for any damage.

Removing the Existing Door

Remove the existing door leaf.

To help reduce the damage to wall decorations and plaster, score around the perimeter of the frame with a craft knife. Saw through the jambs and remove. The best way to do this is by sawing diagonally in the centre and removing them in two sections.

Do not saw them all the way through as this can cause damage to the internal reveals or structure. If there is a chance this will happen, use a bearing block to protect the plaster and render, then lever the jambs away from the walls and complete the cuts.

Remove the top and bottom rails in the same way.

Preparing the Opening

Once the door has been removed, ensure the opening is free from screws, nails, fillers and mastic.

Repair as required in accordance with BPF recommendations.

The opening should be complete before fitting the door.

Check there's a lintel or other load transferring structure fitted above the doorway.

Door Alignment

The positioning of the door within the brickwork is vital to the correct functioning of the door

- Door outerframe set back as far as possible to reduce exposure to elements
- Bridge the wall cavity
- Cover the DPC
- Frame is square and not twisted

Door Set Installation

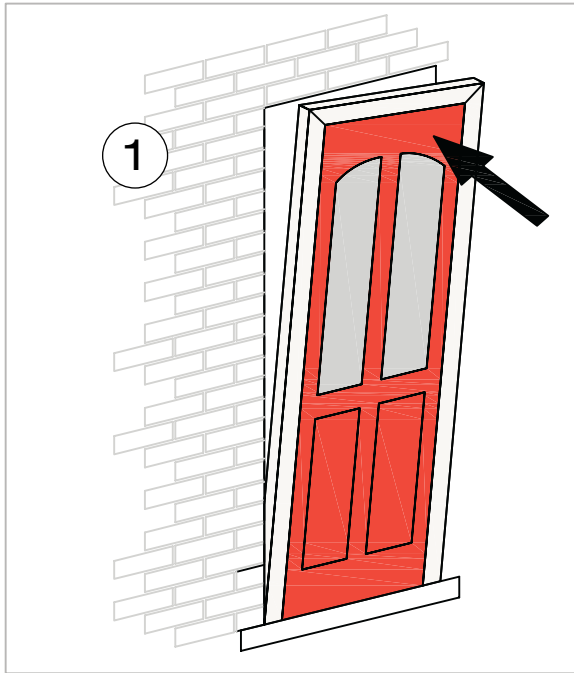

1. Offer complete door unit into brickwork opening.

2. Hold frame into position using appropriate size wedge packers.

Packers must be located adjacent to fixing positions to prevent distortion of the outer frame when frame fixings are tightened.

Failure to adhere to this may result in door function issues.

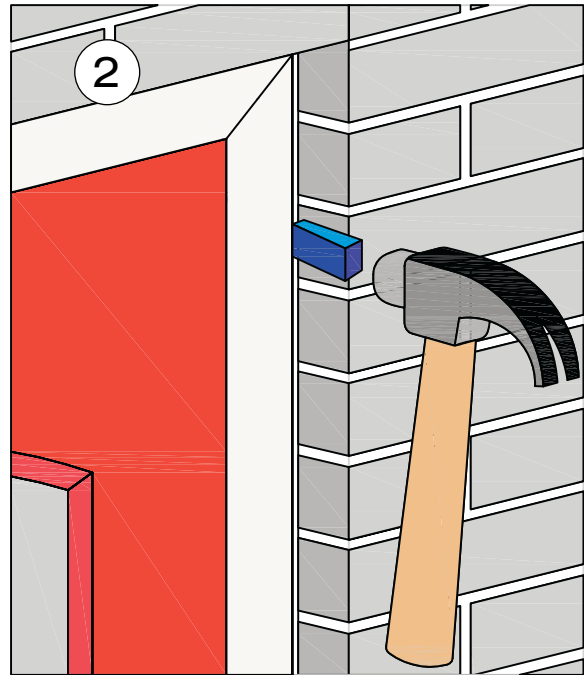

3. Spirit level (1.5m Long) should be used to ensure jambs are square and plumb in all planes.

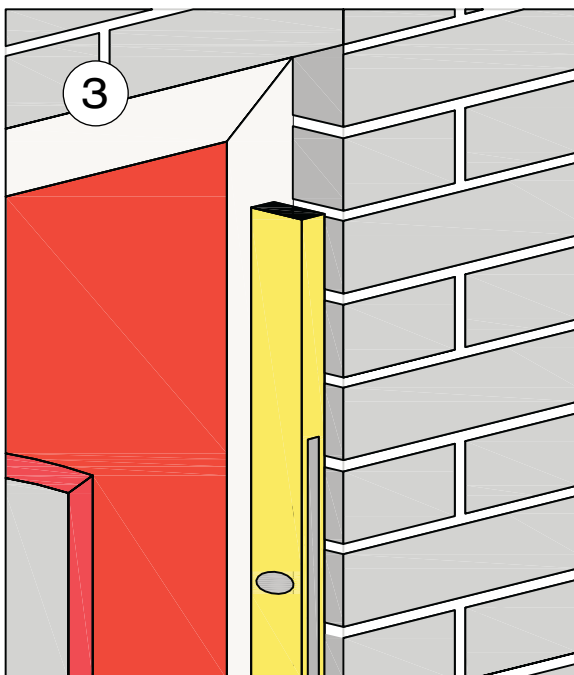

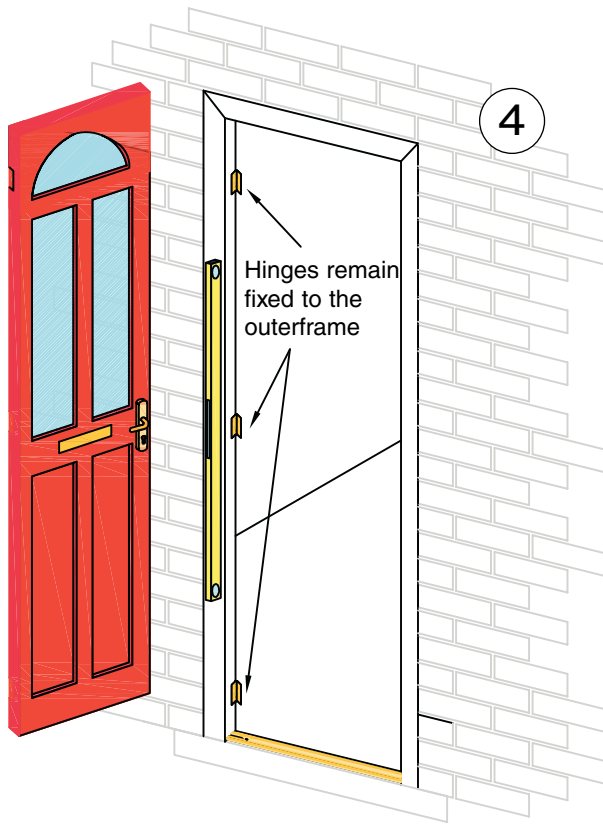

4. It is recommended that you remove the door leaf from the hinges to make the outer frame easier to fix into brickwork aperture. Once square and plumb, fix as per instructions. (See Page 5 for fixings & positions)

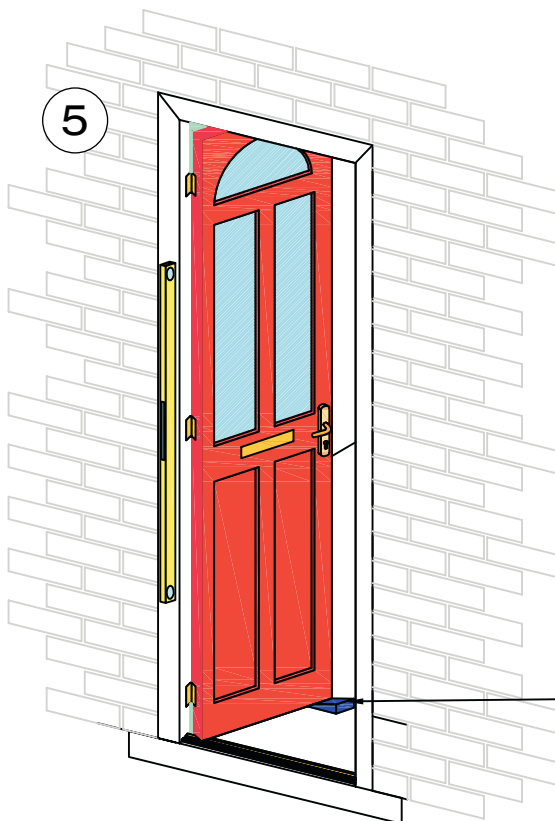

5. Pack the bottom of the door leaf at the leading edge to assist getting square into outerframe.

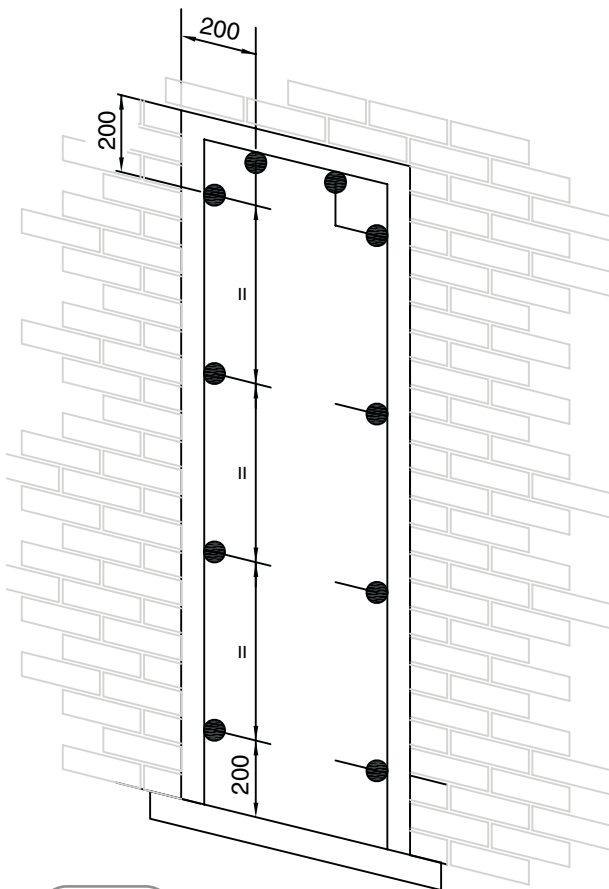

Fixing Positions

These positions are for guidelines only.

Ensure fixings are into secure substrate.
Recommended fixing positions are as follows:

Corner fixings: 150mm minimum and a maximum of 250mm from external corner.

Intermediate fixings: Centres not exceeding 600mm.

Transoms fixing: Should not be closer than 150mm from transom centre line and no greater than 250mm.

The head of the through frame fixing should be located within the hollow chamber (to prevent distortion & cracking of profile)

A clearance hole is required to allow the fixing to pass through the outer skin and covered by a screw cover cap. Alternative fixing may be required due to lintel location.

Drilling

Drill holes through the frame as indicated (ensuring the holes are as recommended by the frame fixing manufacturer)

Secure the frame to the brickwork with suitable frame fixings. Ensure the fixing is secure and correctly positioned in the masonry.

Fixings

The outerframe should be secured into the brickwork using recommended self tapping screws. These should be a minimum of 100mm long and fixed into the masonry by a minimum of 50mm. Tighten and secure all the fixings to ensure the frame is square. Care should be taken not to over-tighten the frame fixings to avoid distortion of the frame.

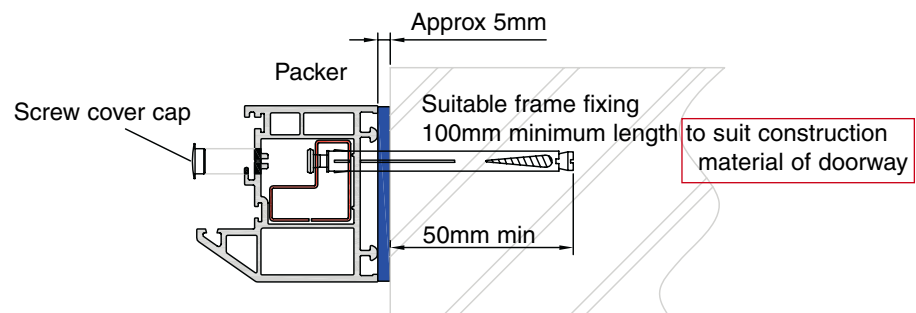

Fixing Side Panel To Main Door Frame

Recommended fixing points are the same as fixing points into the brickwork above.
Pre-drill fixing positions required for transom screw (SH01 4.8 x 65mm)
Apply silicone to the entire length between the PVC-U profile and aluminium coupler on both faces.
The head of the fixing should be located within the hollow chamber.
A clearance hole is needed to allow the fixing to pass through the outer skin and covered by a screw cover cap.
There should be a minimum of 4 fixings each side of the frame coupling profile.
Ensure fixings are staggered to avoid collision on the opposite side of profile.

Fixing Decorative Hardware

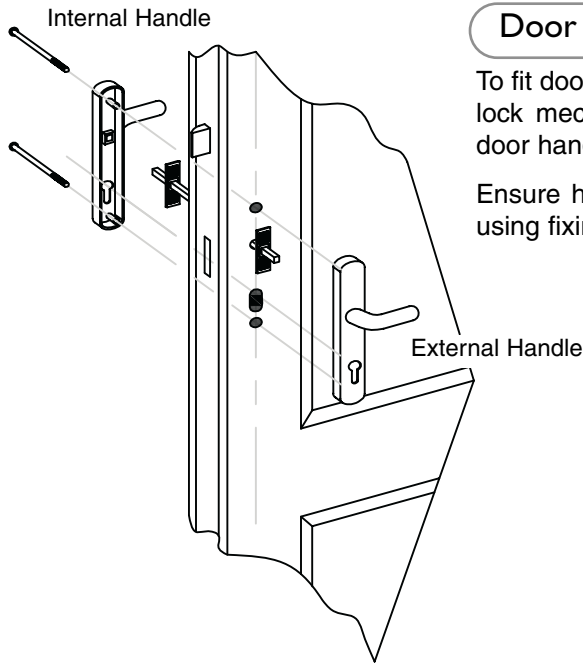

Door Handles

To fit door handle set, locate spindle through square hole in lock mechanism. Align projecting pins on internal half of door handle set with pre-drilled holes in door slab.

Ensure handle spring washers are in position and secure using fixing screws supplied.

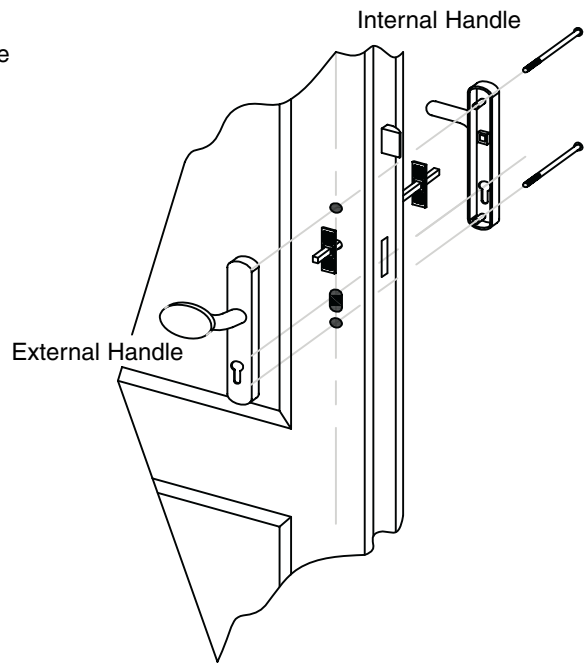

NB: When the door has been fixed into position the operation of the door opening and locking mechanism must be checked to ensure uniform contact with weatherseals and correct function of handle/lock.

Sealing around the Perimeter

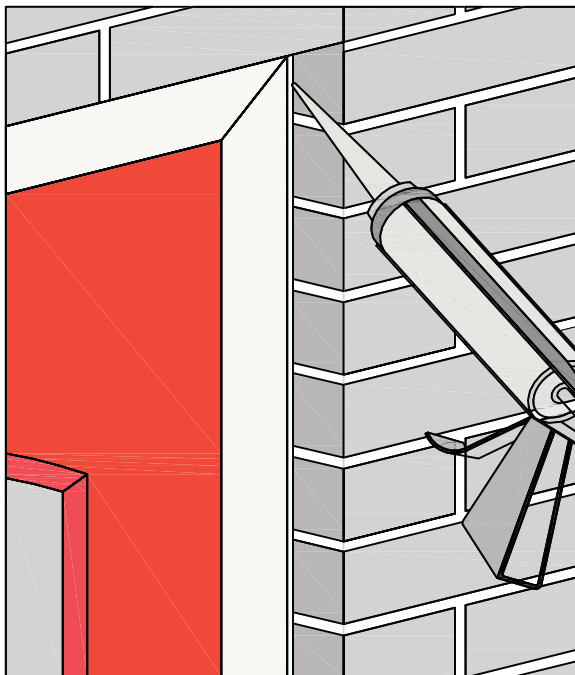

Silicone sealant or similar suitable product should be used to seal around the perimeter of the newly installed composite door frame.

Ensure that an adequate barrier is formed to prevent water ingress/air leakage

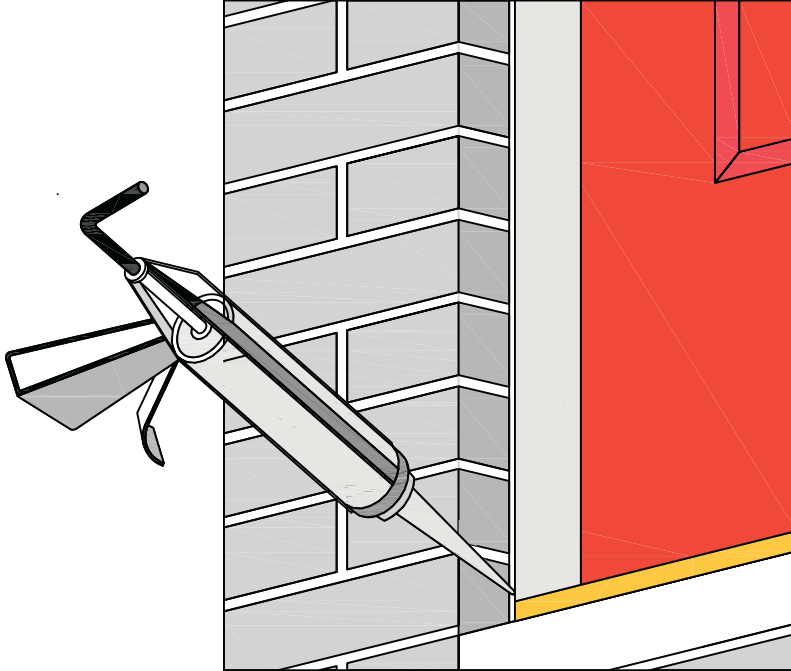

NB: Care must be taken to ensure that the drainage slots are not blocked when sealing around the aluminium Low Threshold.

Fixing Security Chain

The security chain should be positioned into the desired location for ease of use (i.e. to suit the persons who will be required to use the device)

Mark the fixing positions onto the door/frame using the pre-drilled holes in fittings as a template.

Move the security chain and drill pilot holes in the marked positions, use the screws provided to secure.

NB: Care should be taken when the fittings are positioned to ensure the security chain will function correctly.

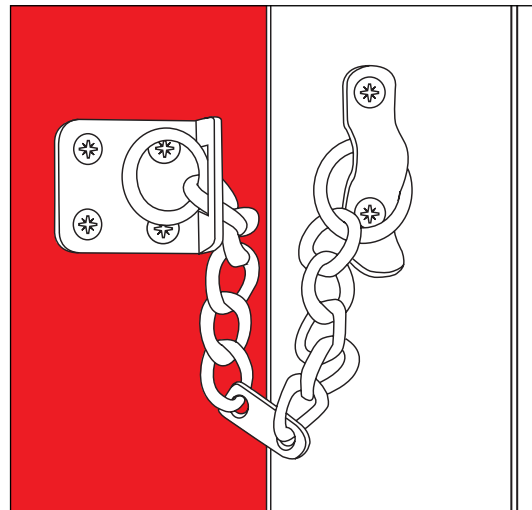

Fixing Decorative Numerals

Numerals should be located in the desired position on the composite door, when satisfied this is correct, the holes in the numerals should be used as a template to mark the required pilot holes to fix.

Drill pilot holes and use the screws provided to secure to the door.