

Slimline Windows

Complete Aluminium
Window System



Aluminium Window Systems

Aluminium is a smart choice for any renovation or homebuilding project. It combines strength and durability in a lightweight material and slim frames, offering clean designs that allow light to flood into your home.

Made to measure, our windows can be manufactured for a variety of glazing solutions including fixed windows, side hung, top hung, open out, sash windows, tilt and turns, angled windows and bay windows. They are all appropriate for both residential and commercial applications.



Our windows are fitted with multi-point steel locking mechanisms that exceed British Standards for security. Key locking handles are supplied on all opening lights.



Allstyle windows and doors are thermally efficient, contributing to a reduction in the cost of heating bills. Warmth and comfort are built in to our window systems.



We are able to manufacture our window products in any RAL colour and with a matte finish. We can provide dual colour RAL coating if you need different colours inside and outside too.



Our aluminium frames will never rot, rust, peel or flake, making them maintenance free. We offer our windows with a 10 year guarantee for your peace of mind - Allstyle windows are a sound investment.



We have a choice of masked trickle ventilation with an integrated head, ensuring that the stylish and slim look of aluminium windows will not be disrupted by visible night vent canopy hoods.

Concealed trickle ventilation

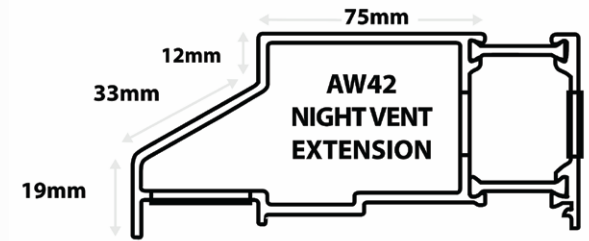

No visible external cover vents



Endless design possibilities

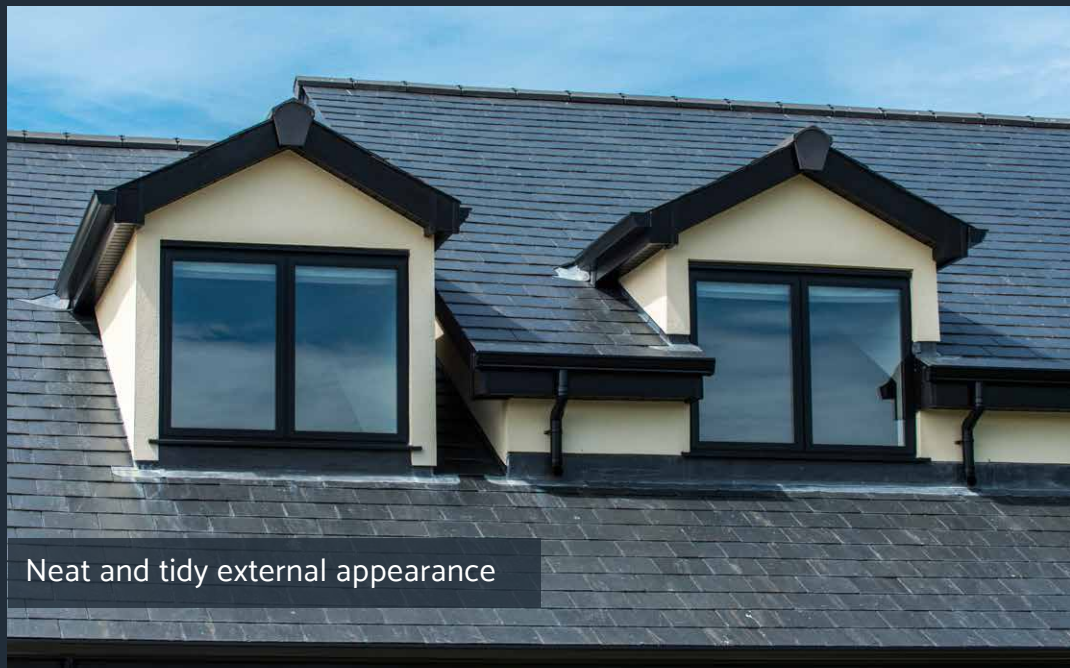

Neat and tidy external appearance



Minimal obstruction internally

Bespoke Solutions

As one of the UK's largest and most experienced manufacturers, the Allstyle team has a wide knowledge base and a vast combined experience in the design and production of a range of truly bespoke glazing solutions.

Contact us today for assistance with your next home improvement, renovation or building project.

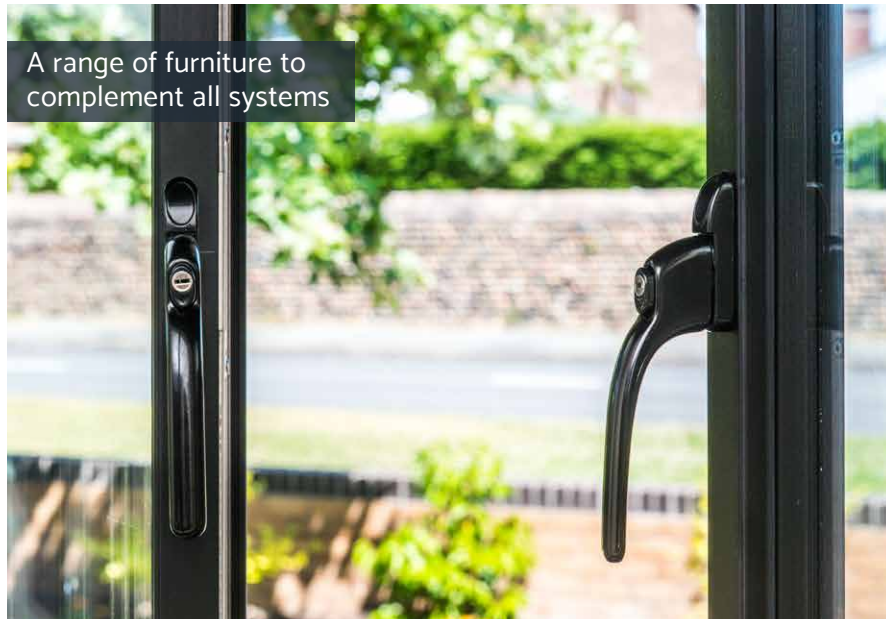

A range of furniture to complement all systems



Sliding patio door with rooflight



Complete aluminium systems



Aluminium Casement Windows

Flush Look Aluminium Window System

We set out to create a window design which is seamless in appearance. Sleek sightlines and fluidity viewed externally the opening sash sits level with the outer frame in the closed position providing a sight line which is much more appealing to the eye than a traditionally made casement window.

Designed for top or side hung opening-out windows, this unique window is manufactured exclusively by Affordable Aluminium Systems Ltd. and can be complemented with a wide selection of hardware to achieve the look you desire.

Key Features & Specifications:

- High-Security bi-directional pincer multi-point mechanism with key lockable night vent position.
- Fully compliant with Doc L of the Building Regulations (Conservation of Fuel and Power).
- Compliance with Document Q
- Window Energy Rating up to A
- Concealed Night Ventilation available where required
- Concealed mullions and Transoms with slim sash to sash sightlines of just 102mm
- The in-line flush look is a perfect match with our bifolding doors.

Sash Sizes

- Top Hung - max. sash size: 1400x1300mm (40kg)
- Friction Stays - (up to and including) 24"
- Side Hung - max. sash size: 700*x1400mm (28kg)
- Friction Stays - (up to and including) 16"
- *800mm with Fire Escape Hinges



View Outside



View Inside

Section Detail

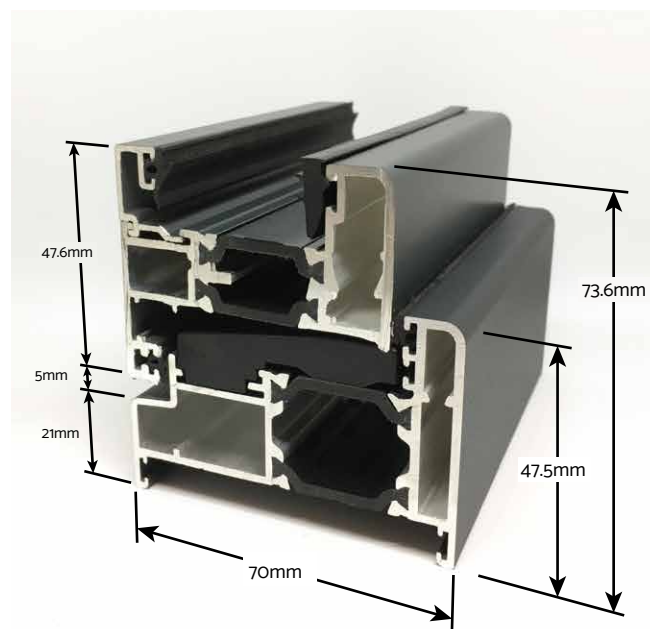

Sash-to-Sash Sightlines

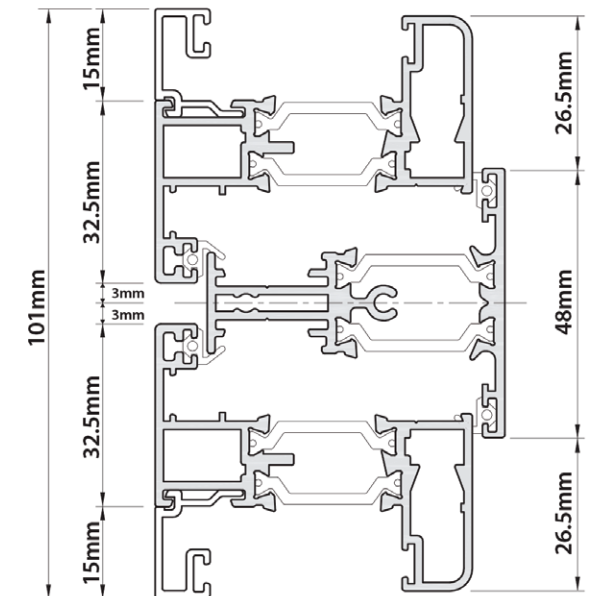

Hardware & Furniture

Tear Drop & Monkey-Tail Handles

With an elegant design that has been inspired by traditional 19th century ironmongery, Tear Drop or Monkey-Tail Handles are the perfect finishing touch for the Flush Look Aluminium Window.

- Strength tested to equivalent of a modern espagnolette window handle
- Strong espagnolette operator
- Manufactured from die-cast zinc with specially formulated finish
- Harder wearing finish than traditional wrought iron furniture
- Matching Tear Drop Dummy and Operating Stays, and Monkey Tail Dummy Stays also available
- Create a perfectly matching heritage window
- Key locking & Security enabled



Espagnolette Handle

- Die cast aluminium lever – The perfect balance of price and performance
- Solid zinc baseplate – Stability and security
- Heavy duty sprung latching block – Positive click on closing
- Long handle with 50mm window clearance – Greater leverage and easy to operate without catching a hand on the window
- Classic design with a contemporary twist – Create an elegant and stylish window
- Patented cover caps with colour coordinated finish – Perfectly matching components, even down to the smallest details.



Tilt & Turn Windows

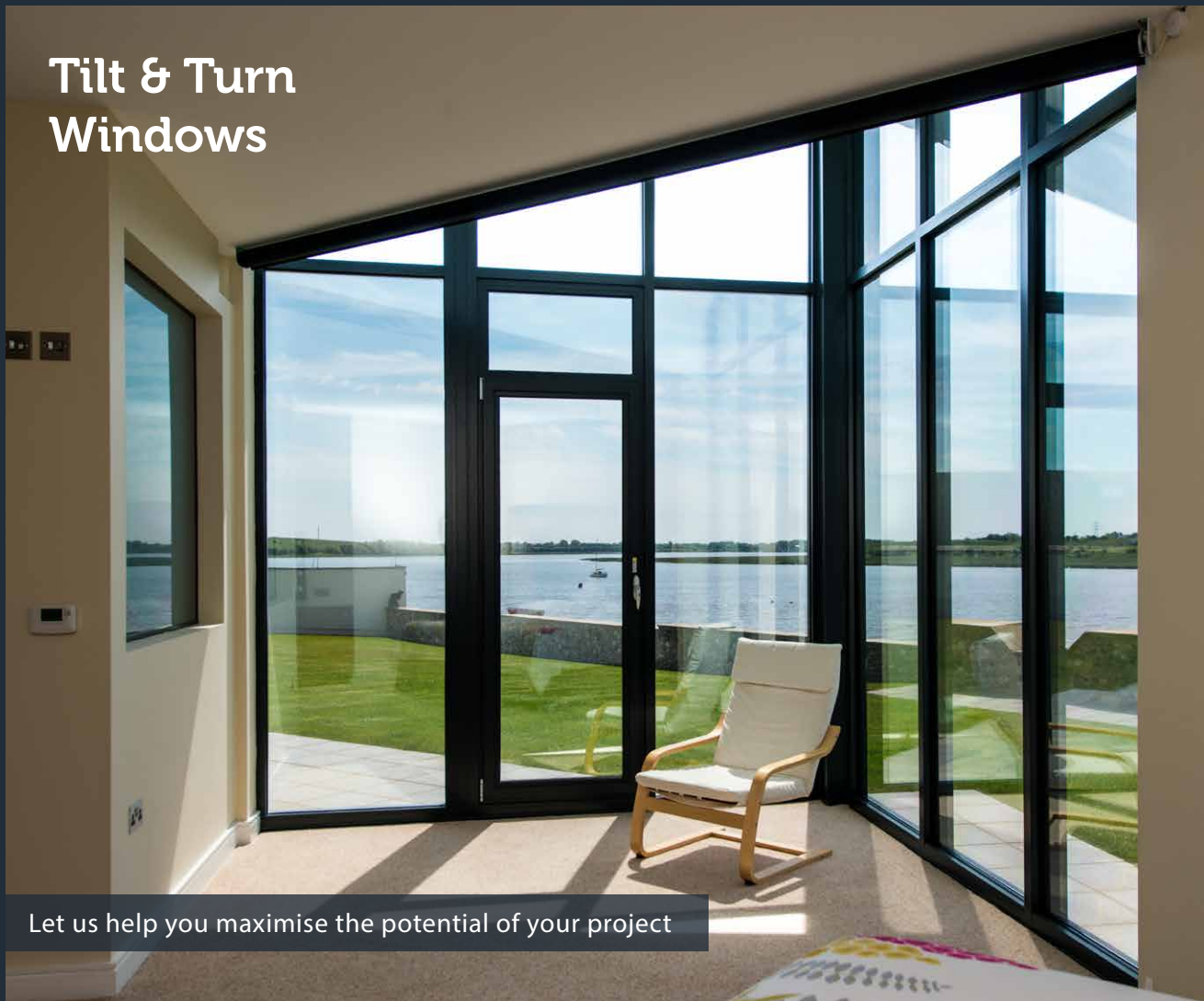

Let us help you maximise the potential of your project

For those looking for a sleek design that can give both excellent ventilation and a much larger opening potential, the Allstyle Tilt and Turn is the way forward. Opening in, Tilt and Turn windows are perfect for a balconies and low level glazing where an open out window just won't do. Larger apertures are also possible with Tilt and Turn.

Allstyle Tilt and Turn windows are available with all of the same matching finishes and fixtures as our other window and door systems.

In the 'Tilt' position, the windows can open inwards from the bottom (as below) allowing you to open windows for ventilation while maintaining security.

The 'Turn' position allows the window to open fully inwards, in the normal way you would, from the side.

Flexibility is the key advantage of Tilt & Turn windows.



A secure ventilation option



Feature rich, modern doors & windows



Available with threshold and cill options too, allowing you to seamlessly blend inside and out. Choose from a rebated (weathered) threshold or low thresher and cills. Bifolds run smoothly inside tracks.



Stainless steel or matching coloured hardware like handles and hinges available. There is optional keyed locking on slave handle(s) to further secure and multi-point locking systems for ultimate security on bifolds.



We are able to powder coat to any RAL colour in both single and dual colour, and can supply a matte finish. A marine grade powder coat is also available if required.



Integrated blinds can be installed within our sealed glass units and are available in a range of colours to complement your windows, doors and decoration.



Integrated blind systems

RAISING



LOWERING

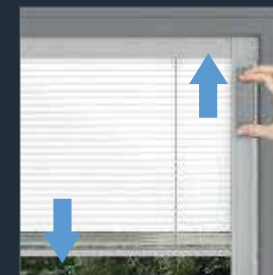

TILTING

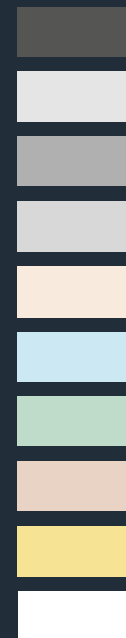

Blinds are operated by a cleverly-designed magnetic slider, placed on the right or left-hand edge of the glass. A narrow adhesive transparent profile ensures the linear movement of the slider. The blind is raised and lowered by moving the slider up or down and is tilted by slightly lifting or lowering the same slider.

For more information, contact:

© Just Value Doors Ltd.

Tel: 01435 515001

Email: sales@justvaluedoors.co.uk

Web: www.justvaluedoors.co.uk

Showroom & Trading address:

Units 2-3 Station Road Industrial Estate,

Browning Road

Heathfield

East Sussex

TN21 8DB

The strength to weight ratio of aluminium allows us to construct frames with slim profiles that look neat and tidy in appearance but allow a lot of natural light into your property. We can also create larger frames in aluminium to reduce sightlines and help you make the most of your home.

Our doors are manufactured from slim thermally broken aluminium profiles which provide strength and security, allowing you to fold and slide the panels back to left or right and open up an unobstructed wide opening to a patio or garden.

Folding doors can be specified with a rebated or low threshold so that two floor levels can remain constant.

Disclaimer: From time to time, dimensions, hardware and designs of our products will change to reflect product development. Accordingly, photographs, drawings, and product dimensions may not always be accurately represented on our website or in brochure material. In addition material colours on our website and brochures are representations only. Printing and computers only show an approximation. Customers should choose colours from actual samples. Before purchasing any product you should check with your us as to the current design, dimension and exact colour of any product.