



For low upvc or low aluminium threshold bi-fold doors

Upvc Bi-fold Installation Guide



Fitting instructions for upvc bi-fold doors with low thresholds

There should be a solid structure to fix the frame jambs to, and above the frame there must be a lintel. No load is to be transferred to any part of the frame.

Perimeter of door-set to be continuously sealed using low modulus, high elasticity sealant.

Debris to be removed from all drainage channels, track and rolling mechanisms.

Step by step...

Special attention should be given when installing the frame.

- 1.** We recommend that the sashes are removed from the frame before starting the installation.
- 2.** Preparation of the opening should ensure that the frame cill is fully supported along its total length.



- 3.** Suitable fixings should be used to secure the frame positioning 150mm to 250mm from each corner, then at a maximum of 600mm centers thereafter. Adequate support should be positioned between the brickwork and frame to prevent distortion when tightening the fixings.



- 4.** The frame cill must be fully supported along its length, level and without twist or distortion. Due to the nature of folding-sliding doors, most being over 2m in width, we would suggest a laser level or string line be used to ensure this.

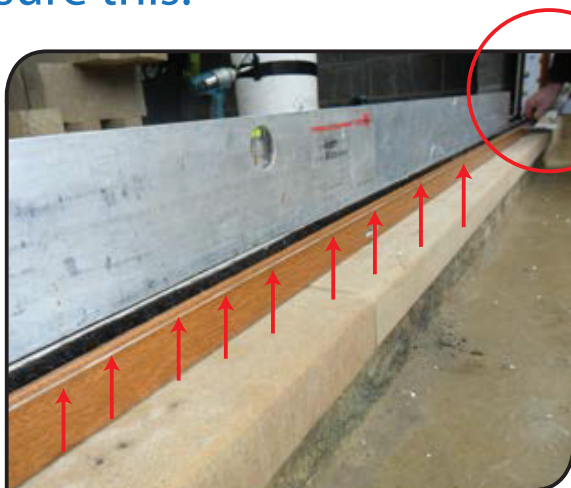

Silicone sealant should be applied to the drilled holes on the frame cill before the fixings are inserted to prevent water seepage.



Level across 2 points indicated

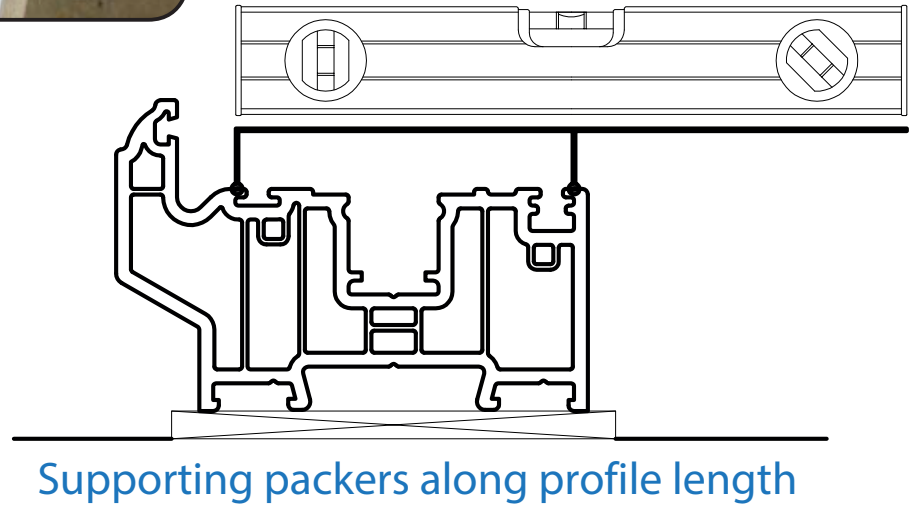

- 5.** The frame jambs should be secured 'in plumb' vertical and without any twist or distortion.



- 6.** The frame head should then be fixed ensuring that it is parallel with the cill, again without twist and distortion. This can be aided by the use of a timber 'lat' or similar, cut to the internal height of the frame rebate and positioned along the width as a guide whilst fixing the head

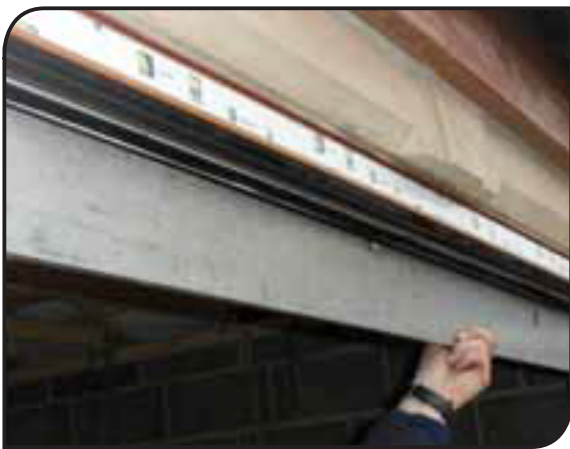

- 7.** A final diagonal check should then be made
- 8.** Replace sashes onto frame.
- 9.** Bottom rollers can then be adjusted (using a 6mm allen key) to give an 8mm gap between the frame and sash edge at the bottom.

Single Roller

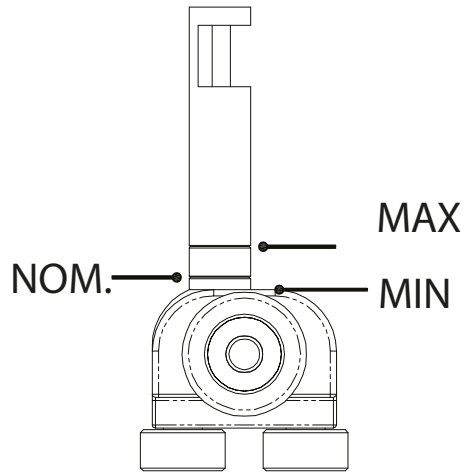

Double Roller

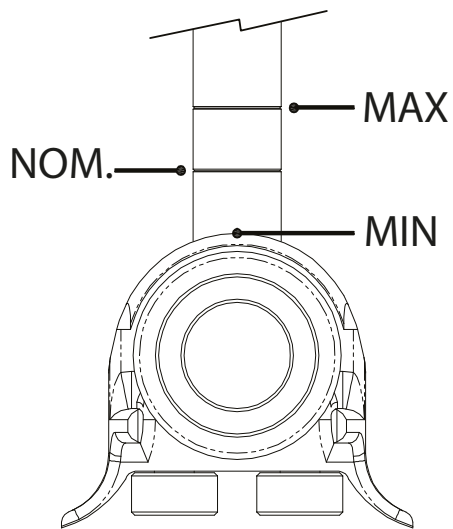

- 10.** Top rollers should be adjusted to maintain compression/contact against the track.

Do not fully lock off the grub screw

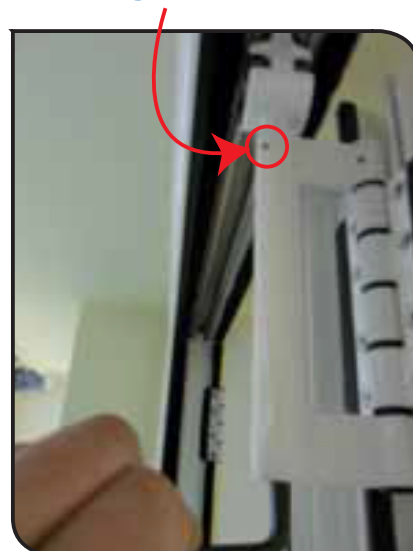

11.

Commence glazing starting with the first hinged door onto the frame. Each unit should be 'toe and heeled'.

All glazing must fall in line with the requirements of BS6262 and any recommendations of the glass manufacturers.

The correct use of glazing packers is critical to allow bi-fold doors to function correctly. The diagram to the bottom left shows both a left and right opening door and the position of the glazing packers. The dashed lines indicate the position of the load bearing packers for all of the typical assemblies.

It is essential that the glass stays in position and we therefore recommend that where necessary, the packers are siliconed into position. Ensure that all packers do not obstruct any drainage holes.

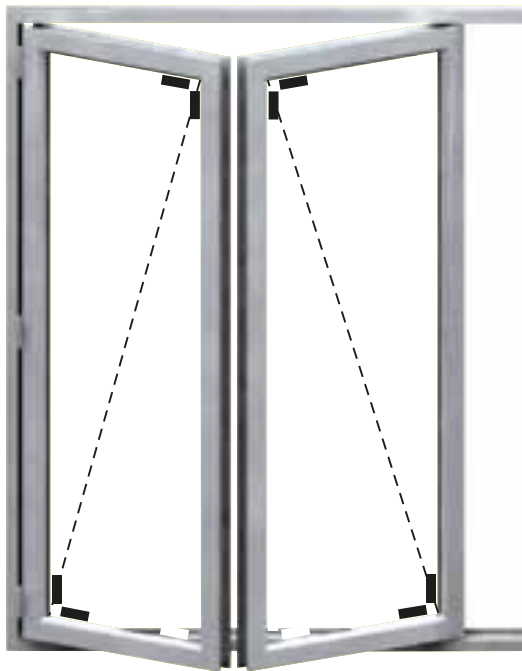

- Load bearing packers to keep door square and level
- Packing to prevent glass movement and provide rigidity to the door

We strongly advise the use of our glazing platforms as illustrated above.

- 12.** The nominal gap between the doors is 8mm. This can be adjusted to a minimum of 6mm and a maximum of 10mm by adding or removing the 1mm shim packers at each hinge point. The hinges have to be unscrewed in order to do this.

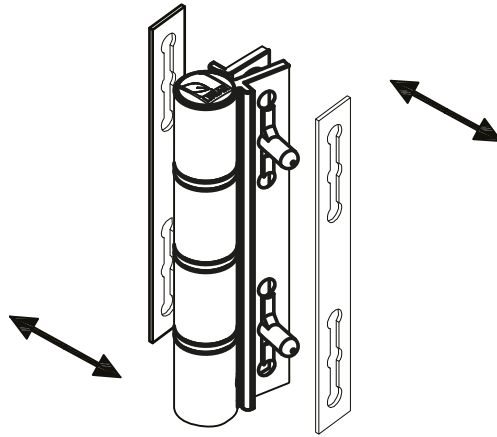

- 13.** Compression adjustment can be made by rotating the cap at the end of the shoot bolts. Loosen the locking screw first then lock off once adjusted

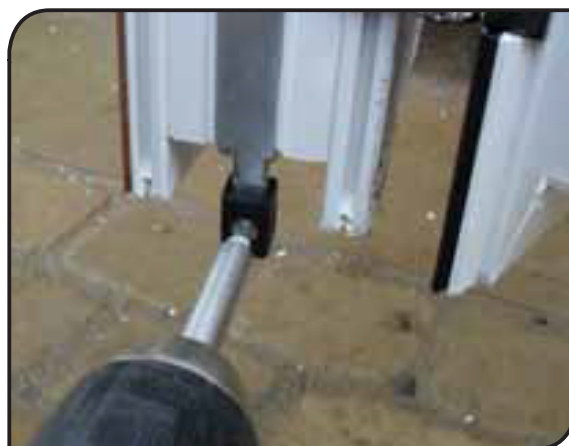

- 14.** Any final adjustment then can be made to the wheel position then lock off the grub screw



- 15.** It is the installer's responsibility to ensure that the end user is informed of the correct opening and closing procedure once the door is complete.

Toe & Heeling

Important Glazing Instructions

In order for all products to work correctly the sealed units must be correctly glazed.

Bi-folding doors must be correctly toe & heeled.

*Example Shown Below
Viewed from the Inside*

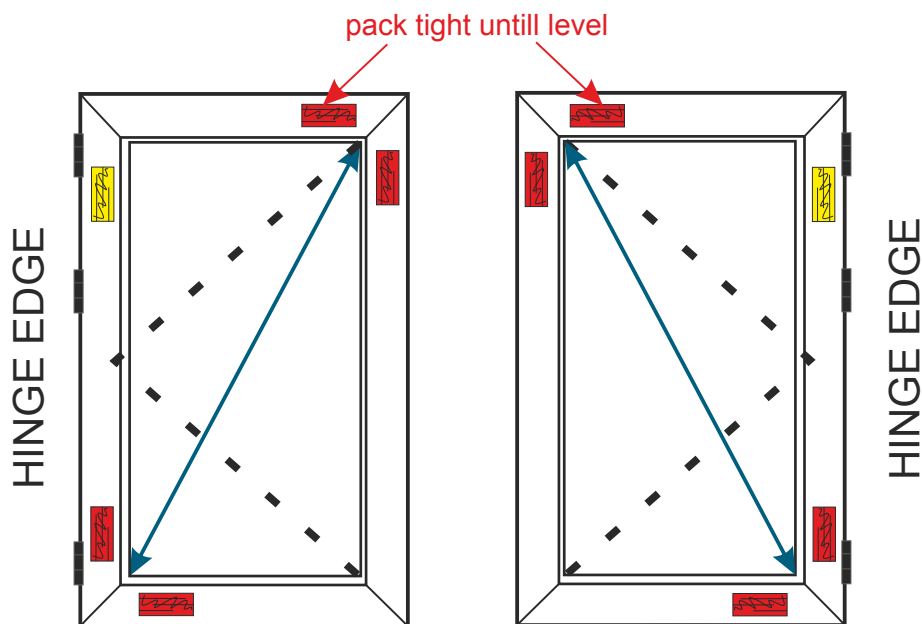

Insert Packers tightly across diagonals, ensure head is level and secure packers in place with silicone.



Internal hinge positions

Packer

Final fix packer

Toe & Heeling

FOLDING / SLIDING OPENING IN OR OUT

| Toe & Heel | |
|---|---|
|  | This symbol indicates where to pack each panel. |
|  | Final Fix Packer |

All configurations are viewed from the Inside

1 Panel

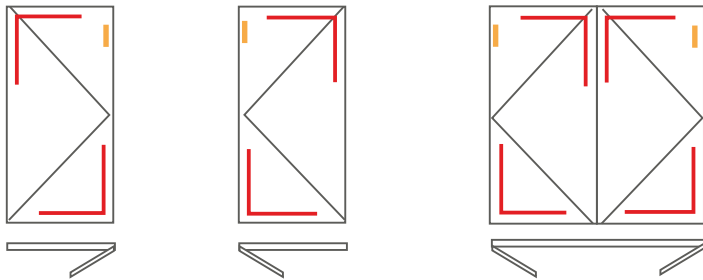

2 Panel

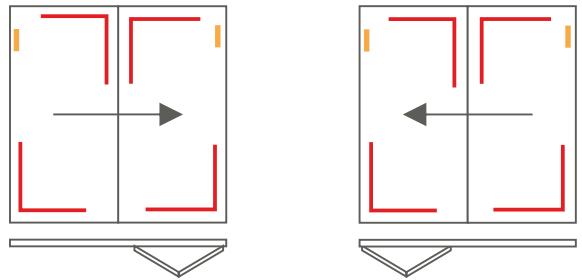

3 Panel

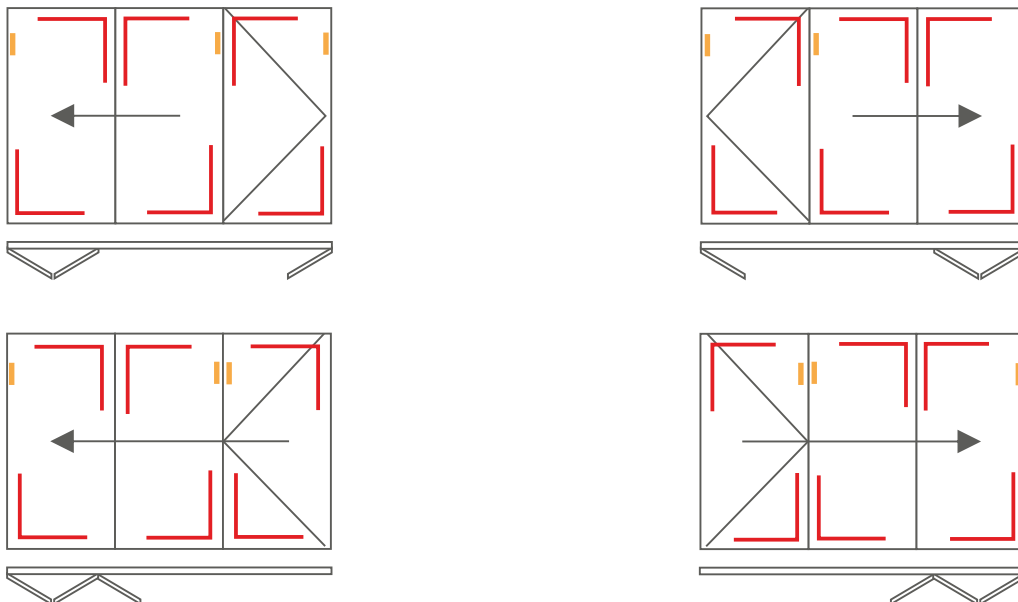

Toe & Heeling

FOLDING / SLIDING OPENING IN OR OUT

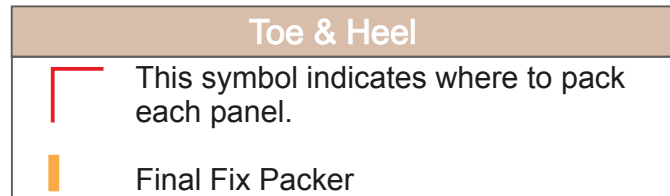

All configurations are viewed from the Inside

4 Panel

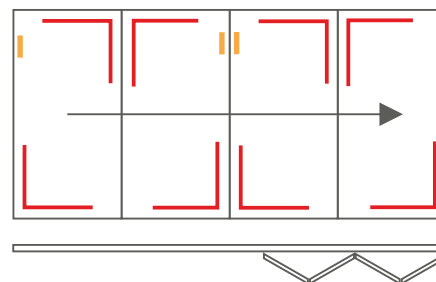
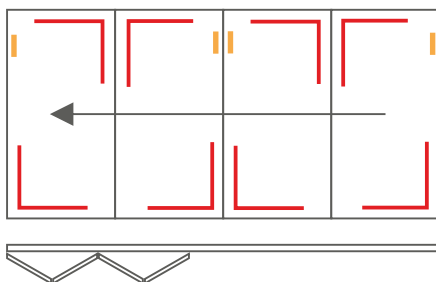
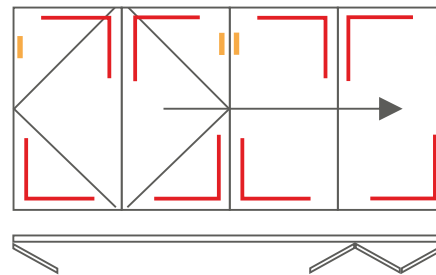
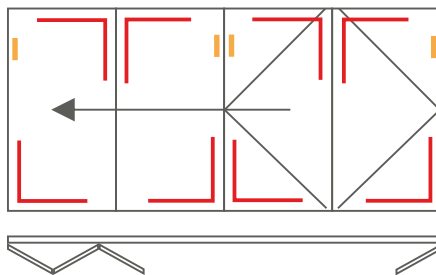
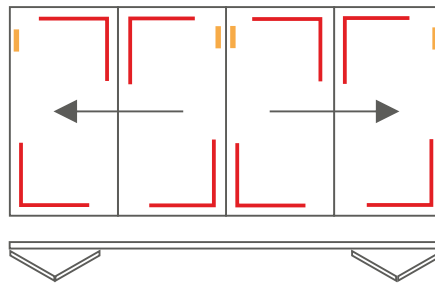

Toe & Heeling

FOLDING / SLIDING OPENING IN OR OUT

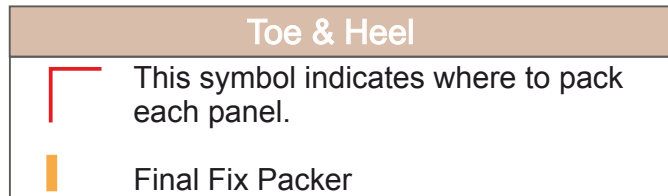

All configurations are viewed from the Inside

5 Panel

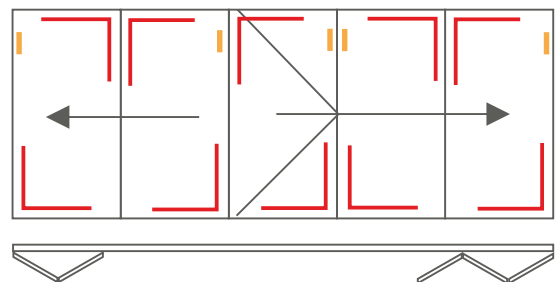
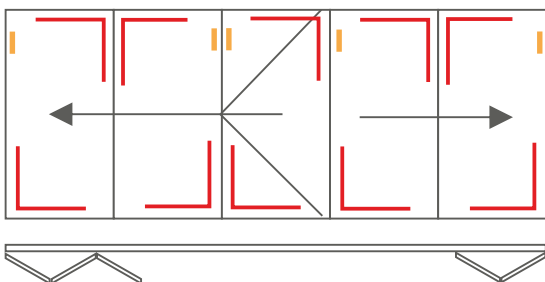
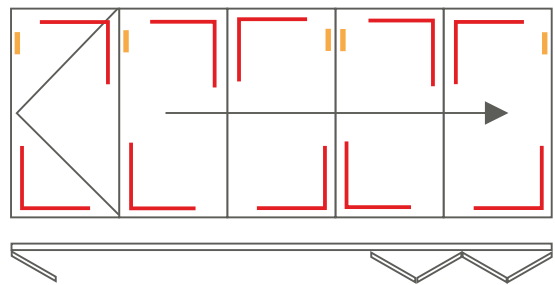
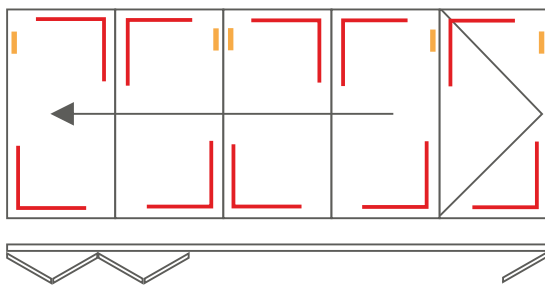
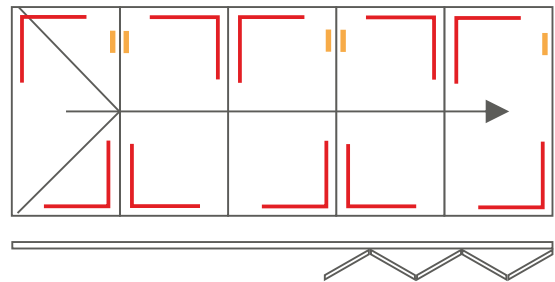
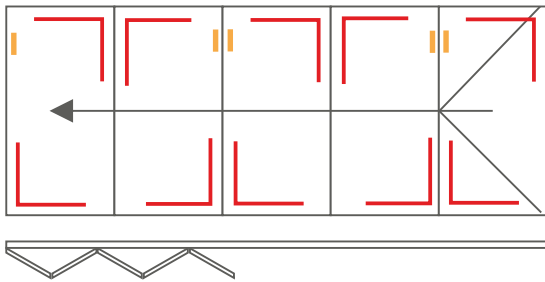

Toe & Heeling

FOLDING / SLIDING OPENING IN OR OUT

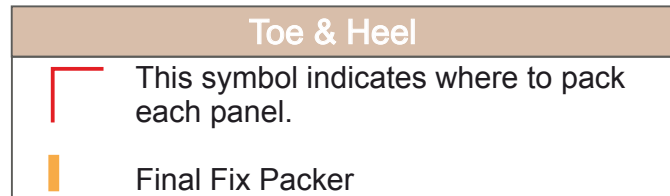

All configurations are viewed from the Inside

6 Panel

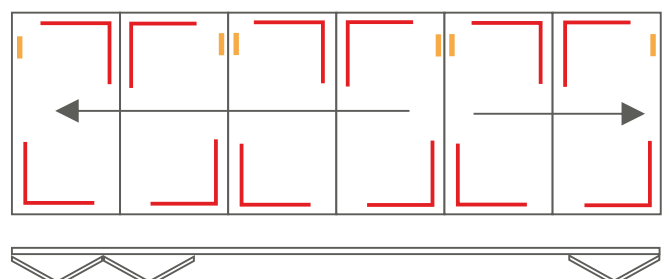
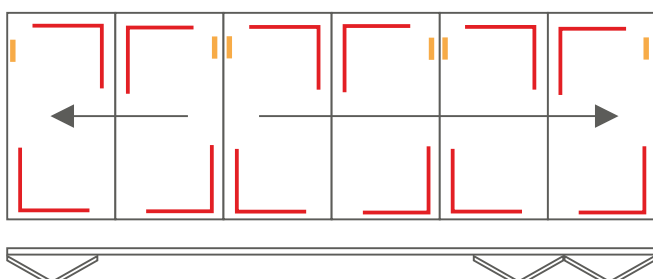
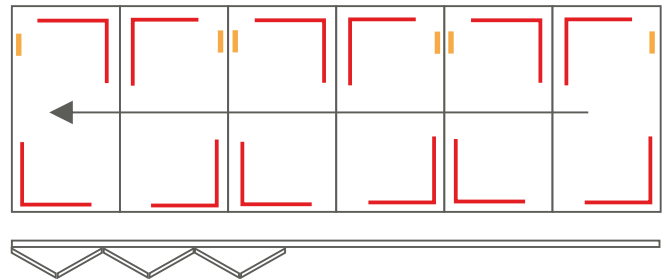
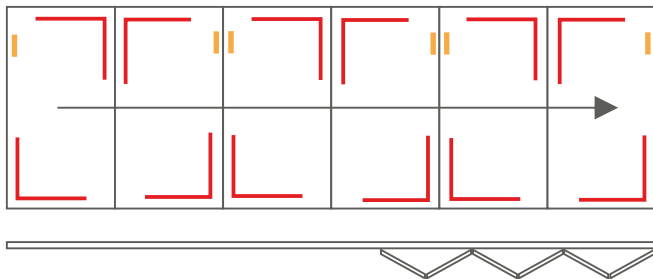
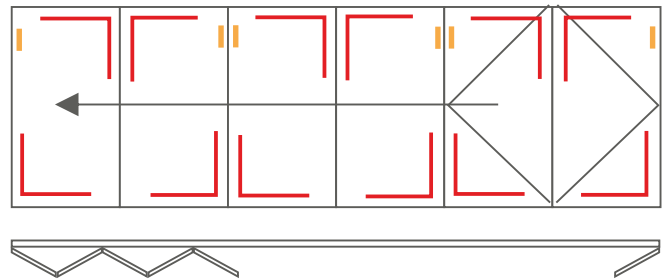
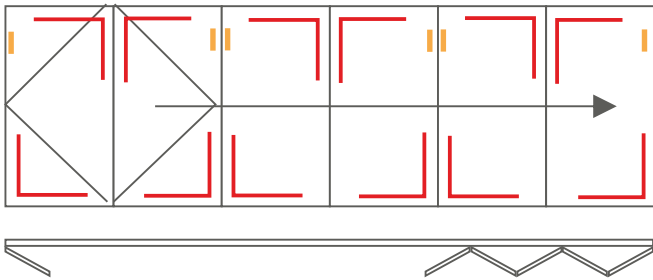
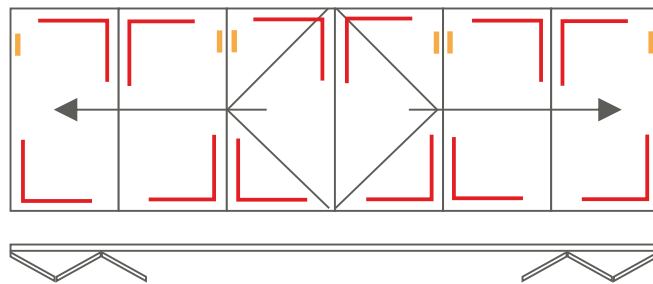

Toe & Heel

FOLDING / SLIDING OPENING IN OR OUT

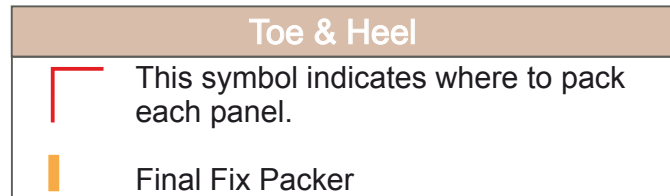

All configurations are viewed from the Inside

7 Panel

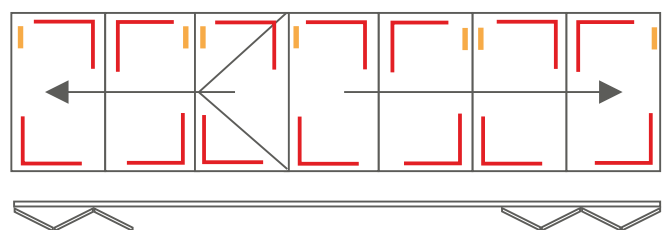
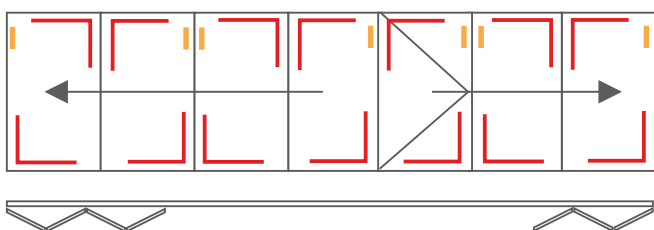
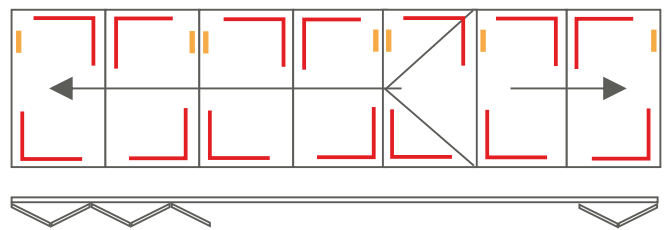
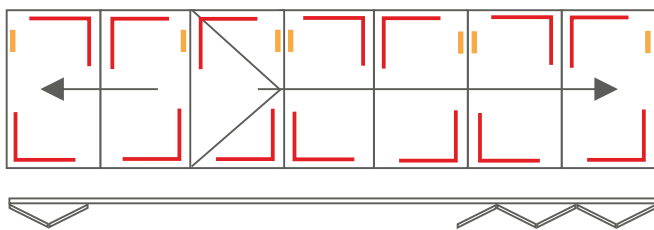
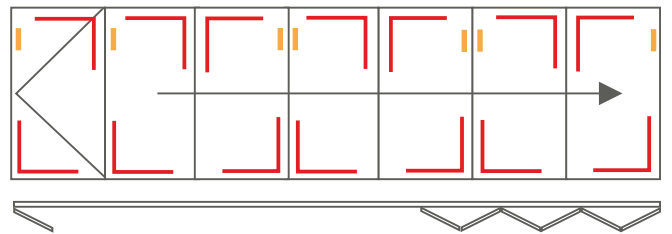
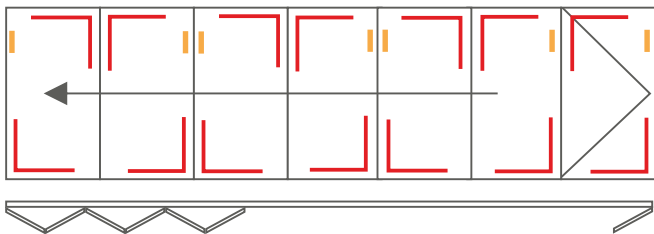
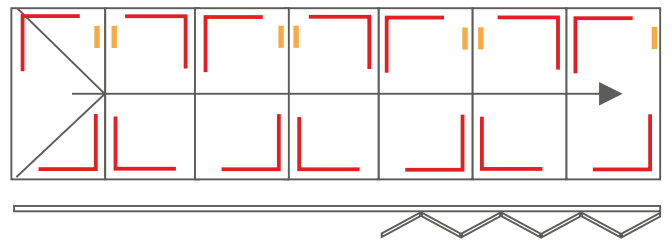
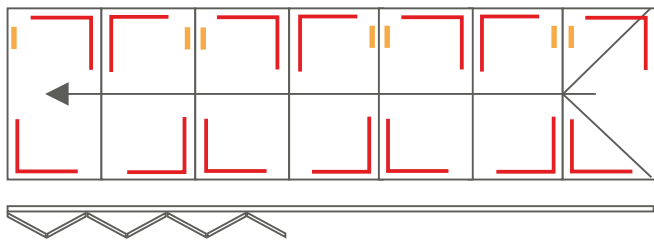

Toe & Heeling

This guide provides a detailed explanation of how we suggest to toe and heel our doors. This is for use as a guide only as each set of doors are unique and may require different levels of packing in the toe and heeling process (amount of packers used). Please use your own judgment.

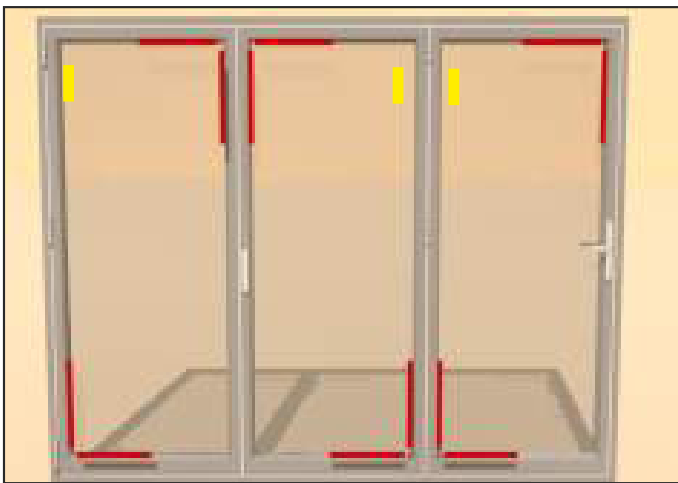

- The red sections display where to toe and heel on a 3 panel door all one way.
- The yellow sections display the final fix packer position.
- Start by toe and heeling the panel attached to the frame first and work towards the traffic door (Or slave door).
- The remainder of the presentation will show you how to toe and heel the traffic door.

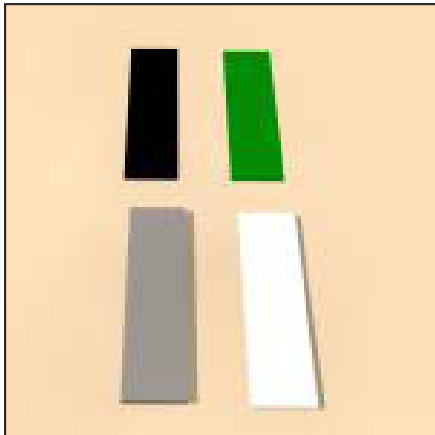

Packers are supplied in a range of sizes which are colour coded for ease of use. Packers used in this guide are an example only. Each door is unique and will require different levels of packing. Always use a range of packers to best suit the door being toe and heeled.



When toe and heeling use a glazing shovel where needed.

Toe & Heeling

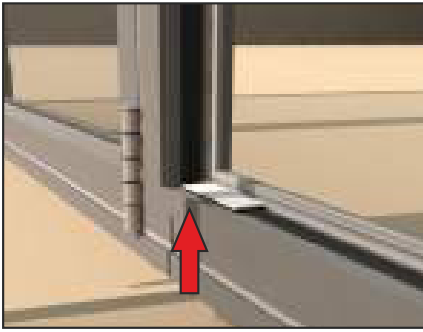

Place 2-3 packers at the bottom of the door on the hinge side (number of packers depends on door tolerances).

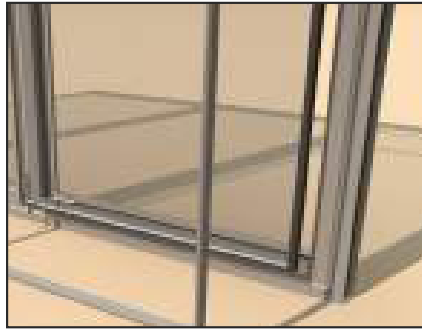

Place glazed unit into door frame.

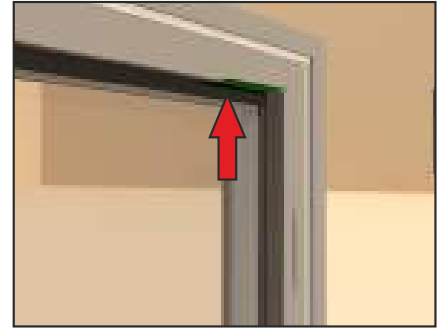

Pack the top of the unit on the handle side of the door. Use a variety of packers until the glazed unit sits firm in place.



Pack the side of the unit on the handle side of the door. Use a variety of packers until the glazed unit sits firm in place and square within the frame.

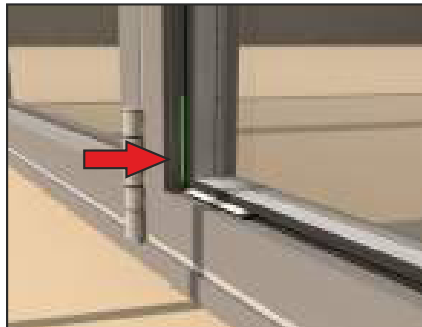

Pack the side of the unit on the hinge side of the door. Use a variety of packers until glazed unit sits firm in place and square within the frame.



Lastly pack the top side corner on the hinge side of the door. Use a variety of packers until the glazed unit sits firm in place. This will help keep the glazed unit square and in place.

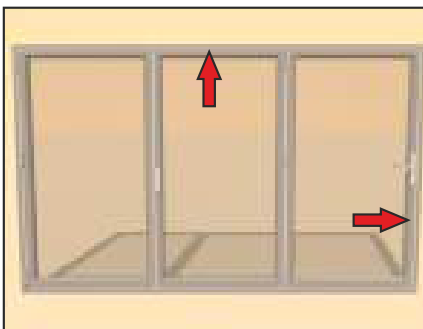

Check door is completely level with the outer frame. If not add or remove packers where needed.

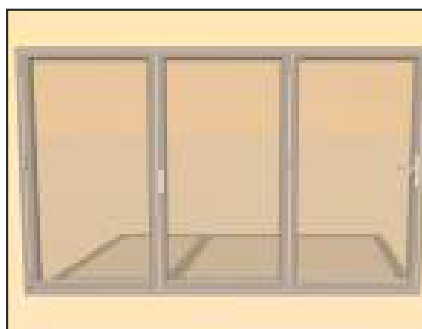

Once all panels have been toe and heeled check door is running correctly and that the locking system works correctly.

If required silicone the packers on the uprights of the door into place. (this will prevent the packers from moving).

Finally clip bead into place.

Operating and maintenance

Opening operation

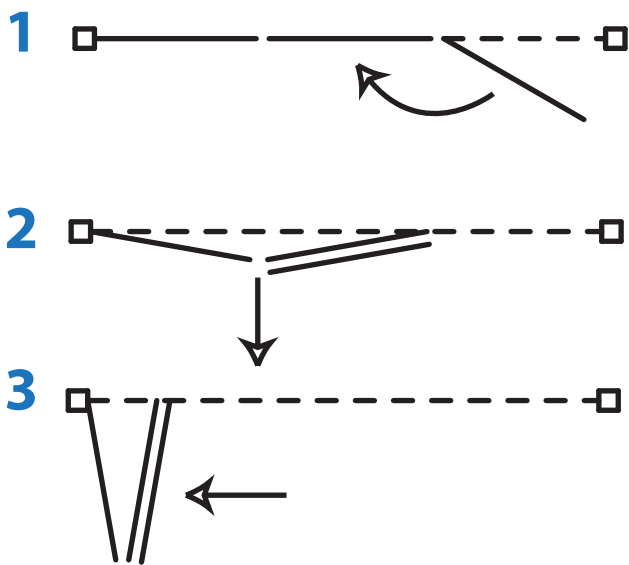

Closing operation

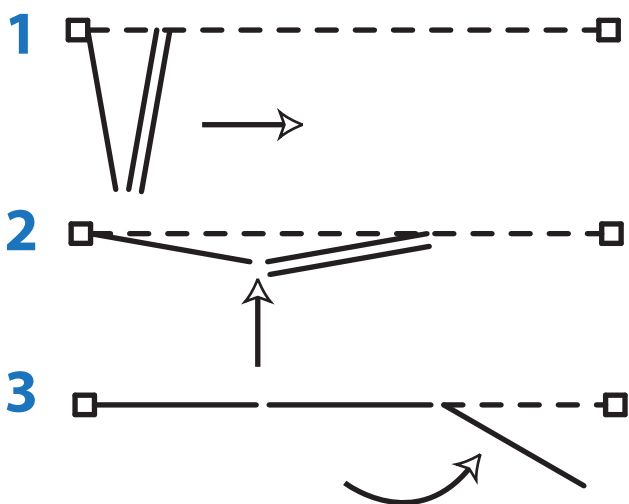

Maintenance

- Roller mechanisms carrying the door panels are fitted with sealed stainless steel bearings and require no lubrication
- Ensure top and bottom tracks are kept free from debris or obstacles which may impair the function of the product.
- Door locking mechanisms to be cleaned and any moving parts to be lubricated with a light machine oil at least once a year and more frequently where appropriate.
- For u-PVC parts clean regularly with soap and water.



Tel: 01435 515001

Web: www.justvaluedoors.co.uk

Email: info@justvaluedoors.co.uk

33A High Street, Heathfield

East Sussex, TN21 8HU